



IVANKA

we cement

FLASTER TILES







IVANKA Concrete FLASTER

Concrete floor/wall tiles for your exteriors and interiors.

designer	Andras Rudolf
manufacturer	IVANKA
year of design	2009
material	IVANKA High Performance Concrete
colour	midnight black, off-white, sky blue, red, grey brown, rock grey, cement, beige, mouse grey, lichen green, ervin grey, sargi yellow

Dimensions

295x295mm and 217x217mm

(Increased with 5mm joint sizes are 300x300 mm and 220x220 mm)

Finishing (half) edge pieces: 150x300 mm and 100x200 mm

Material thickness depending on function: 4,5cm, 2cm, 1 cm

Installation

Recommended receiver area is:

1. gravel and/or sand bed: the exterior tiles can be interlocked with zero joint;
2. cement and sand (mortar), zero to 3mm joints are recommended;
3. flexible tile glue, 1mm to 3mm joints are advised for the grout.

www.ivanka.hu info@ivanka.hu p+36703976182 f+3613338191 Bulcsu utca 13. H-1134 Budapest Hungary

FLASTER by IVANKA

Material

High density fiber reinforced high performance concrete.

The concrete produced by IVANKA is an extremely persistent and resistant material, suitable for indoors and outdoors, domestic and public use. The aging of the concrete product you buy is a natural and aesthetically pleasing characteristic that influences its appearance in a small compass.

Basic Colours

midnight black



rock grey



mouse grey



off-white



cement



lichen green



sky blue



grey brown



ervin grey



red



beige



sargi yellow

More colours coming soon!

Custom colours are also available on request.

Gluing

Given the continuous pattern of the tiles, we recommend laying the tiles cold against one another, but also grouting. When gluing, you can best use a 6 mm glue comb. During laying and grouting, immediately remove any adhesive and other residue. Allow the tiles to dry for at least 3 days prior to impregnation!

Grouting

Joint width zero to 3 mm. We recommend grout 706 from Eurocol; the silver-grey colour delivers the most attractive finish.

It is very important to grout each m², and to immediately remove any excess grout with a wet sponge. After grouting, allow the floor to dry for at least 2 days, ensuring good ventilation.

You can then cover the floor (preferably with linen cloths; absolutely no cardboard) if you have to walk through the room.

Once the floor is clean and dry, first remove all dust. You can then impregnate the floor.

- If you wish, you can pretreat the floor once before grouting, but then apply only one layer on a clean floor, and following treatment, allow the floor to dry thoroughly before grouting.
- If you grout the floor as instructed, no cement scum will arise; never use cement scum remover on cement tiles!

Laying in a bed of sand

The tiles can also be laid in a bed of cement or sand. It is extremely important that you do NOT use black sand but clean river sand. This sand is mixed with cement. The tiles should be laid in the bed of sand extremely moist (as with laying natural stone) to ensure good adhesion. The floor must now be allowed to dry and harden for at least 3 weeks (1 week per cm³ cement bed). First leave the tiles to dry for 3 weeks before impregnating. The cement bed must be at least 3 cm thick. Because the tiles have been thoroughly soaked, the tiles must first be allowed to harden. The tiles are fully hardened after at least one month. During this period, you can of course walk on the floor, but no spot load may be applied. You can best cover the floor with linen cloths, to prevent any dirt being absorbed. If other work has to be carried out in the newly-tiled room, we recommend that you place blankets beneath heavy equipment (ladders, grinding machines, etc.).

1180



Installation using half pieces, with zero joint.

Impregnation

Lithofin MN Dirt solution: using this product you can remove all dirt before treating or maintaining the floor. Faint cement scum can be removed with Lithofin dirt remover MN. If necessary, all product

information can be requested. Lithofin –Vlekstop (anti-stain): for years the best-quality long-term protection against water and stains. Remains invisible. This impregnation is applied to a dry and clean surface with a cloth or mousse roller, until the tiles are saturated. Then, with a dry, non-fluffing cloth, remove any excess product. The product offers optimum protection after 2 days.

Pre-impregnation: by way of pre-impregnation, apply Lithofin anti-stain to the dry tiles (NOT to the edges of the tiles).

Maintenance

For daily maintenance, the floor can be vacuumed and mopped clean. Occasionally, thoroughly clean the floor (rough brushing).

Lithofin gloss and clean ensures a deeper floor gloss.

Once the floor has been impregnated, the upper layer is protected against stains. Nonetheless, we recommend not applying any excess loads to the floor for the first 3 months, until the tiles have dried thoroughly. If further work has to be carried out in the newly-tiled room, please do not leave heavy equipment, ladders, etc. on the floor. We are not liable for any damage.

The floor is low-maintenance and typically takes on a deeper satin gloss after each cleaning. For daily maintenance, simply vacuum and mop the floor.

Always use natural soap D or soft soap

Technical drawing

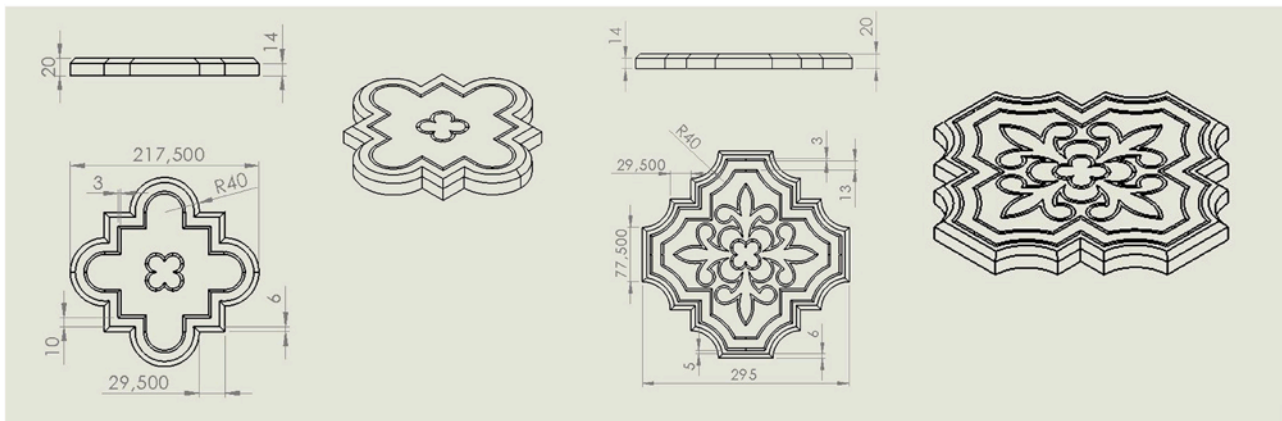

Awards and appreciations

“EDIDA 2009/2010 - Flooring of the year”

IVANKA got Flooring of the Year nomination at Elle Decoration International Design Awards -EDIDA 2010 with ‘FLASTER’ concrete tiles.

“Living Etc Like”

Appreciation given by Living Etc magazine to IVANKA at 100% Design London 2010 for FLASTER Tiles.

